

TUTORIAL 3

DVB-S Standard in a nut shell

Developed by the European Telecommunication Standard Organization (part of ITU), the DVB-S is a standard for satellite video broadcasting. This description is a summary of the standard as described in ETS Document ETS 300 421.

The standard applies only to Ku-band satellites at 11/12 GHz. It is designed to provide Quasi Error Free (QEF) service at BER rates of between 10^{-10} to 10^{-11} . By using a fairly robust error protection scheme which can be varied depending on the channel environment, it can provide this QEF rate to channels with non-corrected error rates of 10^{-1} to 10^{-2} .

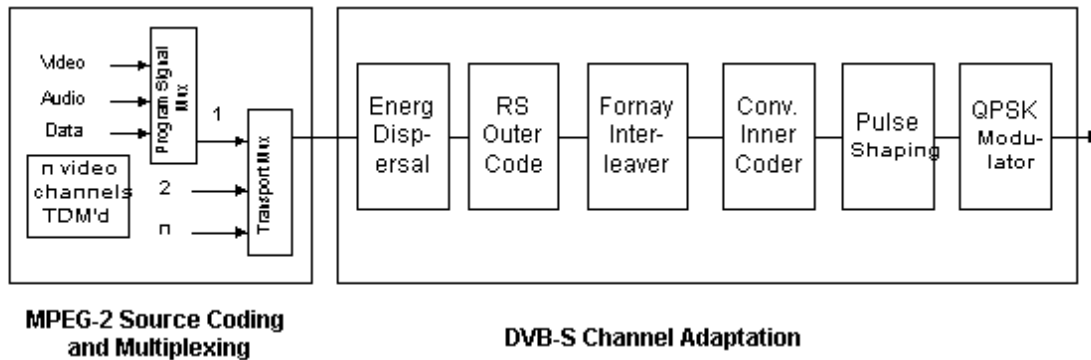

Fig. 1 - Functional Block Diagram of a DVB-S satellite Channel

MPEG Encoding

The MPEG-2 coding/decoding is not part of this standard but requires compatibility. The signals do not need to be MPEG coded but they do need to follow the input interface.

The MPEG Encoder Unit can take in several compressed video channels(which include the program audio and other digital data.) All data is compressed to produce a single MPEG data block of size 188 bytes. MPEG Encoders now exist that can compress together up to 10 regular video channels.

The whole DVB-S system operates in a TDM mode.

Input interface into the DVB-S

The data must be in 188 byte blocks with one byte synch word at the beginning.

Energy Dispersal

The MPEG blocks are shuffled to improve the output spectrum.

Outer Code-Reed Solomon

A (204/188) Reed Solomon Code is applied to the data. This code is capable of correcting 8 errors. It takes the 188 bytes

from the MPEG Encoder and adds 16 additional bytes of overhead. On the receive side, the RS decoder can take in data coming in at app. 10^{-4} BER and convert it to BER of 10^{-10} or better.

Interleaving

The data is then optionally Forney interleaved (convolutional interleaver with depth 12) It is delimited by occasional synch packets. On the receive side, the interleaver provides a gain of app. 3 dB. It improves the ability to correct for large number of burst errors which are missed by the inner convolutional decoder.

Inner Code

The data is then convolutionally coded depending on the transponder size and channel quality desired. (By increasing the code rate, we are reducing the redundancy from the base rate. Increasing the code rate increases the information rate, increases error rate but reduces E_b/N_0 requirements). The basic code rate is $1/2$ with $K=7$. But this rate can be increased by puncturing the code at code rates $2/3$, $3/4$, $5/6$, and $7/8$ and others. Each code rate is tried and then locked on using the synch data.

On the receive side, the convolutional decoder can take in a service quality of 10^{-2} and improve it to an error rate of 10^{-4} .

Baseband Pulse shaping

The baseband pulses are then gray-coded and root raised cosine filtered. The roll-off rate is .35

QPSK Modulation

This single carrier is now QPSK modulated. It is important to note that the modulation is QPSK because we have only a single carrier.

Below a table is given of data rates and transponder sizes. These are guidelines, your system may vary.

Transponder Bandwidth (MHz)	QPSK Symbol Rate (Ms/s)	Coded Bit Rate (Mb/s)	Convolutional Code rate	Reed Solomon Code rate	Information Bit Rate (Mb/s)	E_b/N_0 (dB)
24-27	19.5	39	$5/11 = 0.45$	188/204 (=.922)	16.30	4.00
			$1/2 = .50$		18.00	4.00
			$3/5 = 0.60$		21.60	4.50
			$2/3 = 0.68$		24.40	4.80
			$3/4 = 0.75$		27.00	5.00
			$4/5 = 0.80$		28.80	5.60
			$5/6 = 0.83$		30.00	6.20
			$7/8 = 0.88$		31.40	7.00
36	29.3	59	$5/11 = 0.45$	188/204 (=.922)	24.5	4.00
			$1/2 = .50$		27	4.00
			$3/5 = 0.60$		32.3	4.50
			$2/3 = 0.68$		36.5	4.80
			$3/4 = 0.75$		40.4	5.00
			$4/5 = 0.80$		43.1	5.60
			$5/6 = 0.83$		44.9	6.20
			$7/8 = 0.88$		47.2	7.00

Here are some things to keep in mind. The code rate is dynamically variable. So when link is clean, the transmitter may be transmitting at high code rate (less overhead) but if link deteriorates let's say due to rain fade, the transmitter switches to a higher coder rate to provide the same quality of BER. This means that the system must be designed to operate at the worst condition. To guarantee a certain link quality the system must be able to provide the highest E_b/N_0 listed in the table above.

C. Langton, mntcastle@earthlink.net